



Hoofdstuk 12

Boren, tappen, verzinken

Boren, tappen, verzinken

Dit hoofdstuk bevat producten die in het algemeen bijna overal te koop zijn. Van gewone tot zeer hoge kwaliteit. Ook vindt u hier een scala aan producten die u wellicht in staat stellen opdrachten te combineren met iets uit deze lijst.

Uiteraard kunnen wij u uitstekend bijstaan in de keuze van een speciale tap of boor, die voor een specifiek materiaal geschikt kunnen zijn.

Voor al uw vragen: info@kurval.nl

Inhoud

Spiraalboren type 02.1110 HSS	4
Spiraalboren type 02.1350 HSS	6
Spiraalboren type 02.1360 HSS	12
Spiraalboren type 02.1400 HSS-Co	13
Spiraalboren type 02.1600 HSS-Co	16
HSS Profi spiraalborenssets	20
Machinetappen Enventus® HSS type 03.2050/1	21
Machinetappen Enventus® HSS type 03.3100/1	21
Handtappen Exact® HSS type 03.1120	22
Handtappen Exact® HSS type 03.1220	23
Ronde snijplaten Exact® HSS type 03.7110	25
Ronde snijplaten Exact® HSS type 03.7210	26
Geelring machinetappen Exact® HSS-Co, type 03.2100/1	28
Geelring machinetappen Exact® HSS-Co, type 03.3150/1	28
Geelring machinetappen Exact® HSS-Co, type 03.3500	29
Blauwring machinetappen Exact® HSS-Co, type 03.2250/1	30
Blauwring machinetappen Exact® HSS-Co, type 03.3250/1	30
Blauwring machinetappen Exact® HSS-Co, type 03.3900	31
HSS Machinetappen Sets	32
Verzinkfrees Exact® HSS, type 05.3300	33
Verzinkfrees Exact® HSS TiN gecoat, type 05.3301	34
Verzinkfrees Exact® HSS-Co, type 05.3320	35
Verzinkfrees Exact® HSS-Co TiN gecoat, type 05.3321	35
Verzinkfrees Exact® HSS-Co TiAlN gecoat, type 05.3323	35
Trappenboor Exact® HSS, type 05.6500	36
Trappenboor Exact® HSS, type 05.6501, TiN gecoat	36
Trappenboor Exact® HSS, type 05.6503, TiAlN gecoat	36
Sets Verzinkfreesen	37
Sets Trappenboren	37



Boren

02.1110. PTG Profi HSS spiraalboren

DIN 1897, cilindrische schacht, korte blankgeslepen uitvoering, met kruisaanslijping vanaf 2mm, tophoek 118°

Spiraalboren type 02.1110 HSS

	Ø mm	totale lengte mm	snijlengte mm	verp. eenh.	artikelnr.
	1,0	26	6	10	02.1110.0100
	1,5	32	9	10	02.1110.0150
	2,0	38	12	10	02.1110.0200
	2,1	38	12	10	02.1110.0210
	2,2	40	13	10	02.1110.0220
	2,3	40	13	10	02.1110.0230
	2,4	43	14	10	02.1110.0240
	2,5	43	14	10	02.1110.0250
	2,6	43	14	10	02.1110.0260
	2,7	46	16	10	02.1110.0270
	2,8	46	16	10	02.1110.0280
	2,9	46	16	10	02.1110.0290
	3,0	46	16	10	02.1110.0300
	3,1	49	18	10	02.1110.0310
	3,2	49	18	10	02.1110.0320
	3,3	49	18	10	02.1110.0330
	3,4	52	20	10	02.1110.0340
	3,5	52	20	10	02.1110.0350
	3,6	52	20	10	02.1110.0360
	3,7	52	20	10	02.1110.0370
	3,8	55	22	10	02.1110.0380
	3,9	55	22	10	02.1110.0390
	4,0	55	22	10	02.1110.0400
	4,1	55	22	10	02.1110.0410
	4,2	55	22	10	02.1110.0420
	4,3	58	24	10	02.1110.0430
	4,4	58	24	10	02.1110.0440
	4,5	58	24	10	02.1110.0450
	4,6	58	24	10	02.1110.0460
	4,7	58	24	10	02.1110.0470
	4,8	62	26	10	02.1110.0480
	4,9	62	26	10	02.1110.0490
	5,0	62	26	10	02.1110.0500
	5,1	62	26	10	02.1110.0510
	5,2	62	26	10	02.1110.0520
	5,3	62	26	10	02.1110.0530
	5,4	66	28	10	02.1110.0540
	5,5	66	28	10	02.1110.0550
	5,6	66	28	10	02.1110.0560
	5,7	66	28	10	02.1110.0570
	5,8	66	28	10	02.1110.0580
	5,9	66	28	10	02.1110.0590
	6,0	66	28	10	02.1110.0600
	6,5	70	31	10	02.1110.0650
	6,8	74	34	5	02.1110.0680

**DIN
1897**

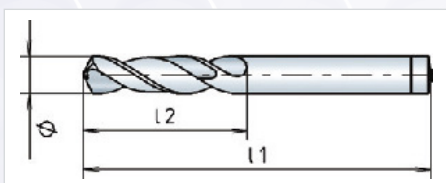



Boren

02.1110. PTG Profi HSS spiraalboren

DIN 1897, cilindrische schacht, korte blankgeslepen uitvoering, met kruisaanslijping vanaf 2mm, tophoek 118°

Spiraalboren type 02.1110 HSS

	Ø mm	totale lengte mm	snijlengte mm	verp. eenh.	artikelnr.
	7,0	74	34	5	02.1110.0700
	7,5	74	34	5	02.1110.0750
	8,0	79	37	5	02.1110.0800
	8,5	79	37	5	02.1110.0850
	9,0	84	40	5	02.1110.0900
	9,5	84	40	5	02.1110.0950
	10,0	89	43	5	02.1110.1000
	10,2	89	43	5	02.1110.1020
	10,5	89	43	5	02.1110.1050
	11,0	95	47	5	02.1110.1100
	11,5	95	47	5	02.1110.1150
	12,0	102	51	5	02.1110.1200
	12,5	102	51	5	02.1110.1250
	13,0	102	51	5	02.1110.1300
	14,0	107	54	5	02.1110.1400
	15,0	111	56	5	02.1110.1500
	16,0	115	58	5	02.1110.1600

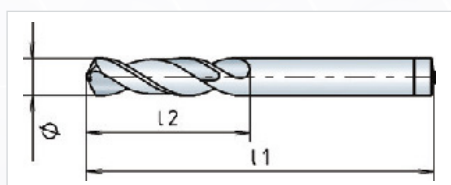

**Boren****02.1350. PTG Ratio HSS spiraalboren**

DIN 338, cilindrische schacht, blankgeslepen uitvoering, met kruisaanslijping vanaf 2mm, tophoek 118°

Spiraalboren type 02.1350 HSS

	Ø mm	totale lengte mm	snijlengte mm	verp. eenh.	artikelnr.
	1,0	34	12	10	02.1350.0100
	1,1	36	14	10	02.1350.0110
	1,2	38	16	10	02.1350.0120
	1,3	38	16	10	02.1350.0130
	1,4	40	18	10	02.1350.0140
	1,5	40	18	10	02.1350.0150
	1,6	43	20	10	02.1350.0160
	1,7	43	20	10	02.1350.0170
	1,8	46	22	10	02.1350.0180
	1,9	46	22	10	02.1350.0190
	2,0	49	24	10	02.1350.0200
	2,1	49	24	10	02.1350.0210
	2,2	53	27	10	02.1350.0220
	2,3	53	27	10	02.1350.0230
	2,4	57	30	10	02.1350.0240
	2,5	57	30	10	02.1350.0250
	2,6	57	30	10	02.1350.0260
	2,7	61	33	10	02.1350.0270
	2,8	61	33	10	02.1350.0280
	2,9	61	33	10	02.1350.0290
	3,0	61	33	10	02.1350.0300
	3,1	65	36	10	02.1350.0310
	3,2	65	36	10	02.1350.0320
	3,3	65	36	10	02.1350.0330
	3,4	70	39	10	02.1350.0340
	3,5	70	39	10	02.1350.0350
	3,6	70	39	10	02.1350.0360
	3,7	70	39	10	02.1350.0370
	3,8	75	43	10	02.1350.0380
	3,9	75	43	10	02.1350.0390
	4,0	75	43	10	02.1350.0400
	4,1	75	43	10	02.1350.0410
	4,2	75	43	10	02.1350.0420
	4,3	80	47	10	02.1350.0430
	4,4	80	47	10	02.1350.0440
	4,5	80	47	10	02.1350.0450
	4,6	80	47	10	02.1350.0460
	4,7	80	47	10	02.1350.0470
	4,8	86	52	10	02.1350.0480
	4,9	86	52	10	02.1350.0490
	5,0	86	52	10	02.1350.0500
	5,1	86	52	10	02.1350.0510
	5,2	86	52	10	02.1350.0520
	5,3	86	52	10	02.1350.0530
	5,4	93	57	10	02.1350.0540
	5,5	93	57	10	02.1350.0550

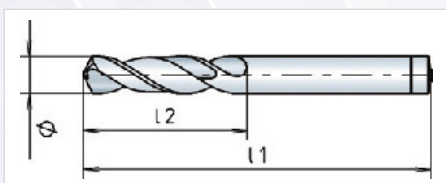
**DIN
338**



Boren

02.1350. PTG Ratio HSS spiraalboren

DIN 338, cilindrische schacht, blankgeslepen uitvoering, met kruisaanslijping vanaf 2mm, tophoek 118°

Spiraalboren type 02.1350 HSS

	Ø mm	totale lengte mm	snijlengte mm	verp. eenh.	artikelnr.
	5,6	93	57	10	02.1350.0560
	5,7	93	57	10	02.1350.0570
	5,8	93	57	10	02.1350.0580
	5,9	93	57	10	02.1350.0590
	6,0	93	57	10	02.1350.0600
	6,1	101	63	10	02.1350.0610
	6,2	101	63	10	02.1350.0620
	6,3	101	63	10	02.1350.0630
	6,4	101	63	10	02.1350.0640
	6,5	101	63	10	02.1350.0650
	6,6	101	63	10	02.1350.0660
	6,7	101	63	10	02.1350.0670
	6,8	109	69	10	02.1350.0680
	6,9	109	69	10	02.1350.0690
	7,0	109	69	10	02.1350.0700
	7,1	109	69	10	02.1350.0710
	7,2	109	69	10	02.1350.0720
	7,3	109	69	10	02.1350.0730
	7,4	109	69	10	02.1350.0740
	7,5	109	69	10	02.1350.0750
	7,6	117	75	10	02.1350.0760
	7,7	117	75	10	02.1350.0770
	7,8	117	75	10	02.1350.0780
	7,9	117	75	10	02.1350.0790
	8,0	117	75	10	02.1350.0800
	8,1	117	75	10	02.1350.0810
	8,2	117	75	10	02.1350.0820
	8,3	117	75	10	02.1350.0830
	8,4	117	75	10	02.1350.0840
	8,5	117	75	10	02.1350.0850
	8,6	125	81	10	02.1350.0860
	8,7	125	81	10	02.1350.0870
	8,8	125	81	10	02.1350.0880
	8,9	125	81	10	02.1350.0890
	9,0	125	81	10	02.1350.0900
	9,1	125	81	10	02.1350.0910
	9,2	125	81	10	02.1350.0920
	9,3	125	81	10	02.1350.0930
	9,4	125	81	10	02.1350.0940
	9,5	125	81	10	02.1350.0950
	9,6	125	81	10	02.1350.0960
	9,7	133	87	10	02.1350.0970
	9,8	133	87	10	02.1350.0980
	9,9	133	87	10	02.1350.0990
	10,0	133	87	10	02.1350.1000
	10,1	133	87	10	02.1350.1010

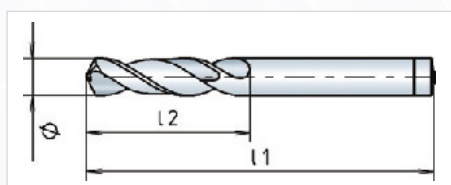
DIN
338

**Boren****02.1350. PTG Ratio HSS spiraalboren**

DIN 338, cilindrische schacht, blankgeslepen uitvoering, met kruisaanslijping vanaf 2mm, tophoek 118°

Spiraalboren type 02.1350 HSS

	Ø mm	totale lengte mm	snijlengte mm	verp. eenh.	artikelnr.
	10,2	133	87	10	02.1350.1020
	10,3	133	87	10	02.1350.1030
	10,4	133	87	10	02.1350.1040
	10,5	133	87	10	02.1350.1050
	10,6	142	94	5	02.1350.1060
	10,7	142	94	5	02.1350.1070
	10,8	142	94	5	02.1350.1080
	10,9	142	94	5	02.1350.1090
	11,0	142	94	5	02.1350.1100
	11,2	142	94	5	02.1350.1120
	11,5	142	94	5	02.1350.1150
	11,8	142	94	5	02.1350.1180
	12,0	151	101	5	02.1350.1200
	12,2	151	101	5	02.1350.1220
	12,5	151	101	5	02.1350.1250
	12,8	151	101	5	02.1350.1280
	13,0	151	101	5	02.1350.1300
	13,5	160	108	5	02.1350.1350
	14,0	160	108	5	02.1350.1400
	14,5	169	114	5	02.1350.1450
	15,0	169	114	5	02.1350.1500
	15,5	178	120	5	02.1350.1550
	16,0	178	120	5	02.1350.1600

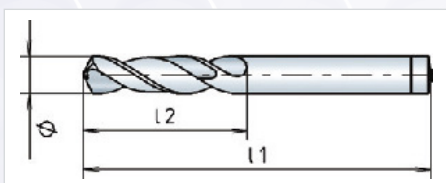
**DIN
338**



Boren

02.1360. PTG Profi Super HSS spiraalboren

DIN 338, cilindrische schacht, blankgeslepen uitvoering, met kruisaanslijping vanaf 2mm, tophoek 118°.
Verpakt in blauwe kunststof box.

Spiraalboren type 02.1360 HSS

	Ø mm	totale lengte mm	snijlengte mm	verp. eenh.	artikelnr.
	0,3	19	3	10	02.1360.0030
	0,4	20	5	10	02.1360.0040
	0,5	22	6	10	02.1360.0050
	0,6	25	7	10	02.1360.0060
	0,7	28	9	10	02.1360.0070
	0,8	30	10	10	02.1360.0080
	0,9	32	11	10	02.1360.0090
	1	34	12	10	02.1360.0100
	1,1	36	14	10	02.1360.0110
	1,2	38	16	10	02.1360.0120
	1,25	38	16	10	02.1360.0125
	1,3	38	16	10	02.1360.0130
	1,4	40	18	10	02.1360.0140
	1,5	40	18	10	02.1360.0150
	1,6	43	20	10	02.1360.0160
	1,7	43	20	10	02.1360.0170
	1,75	46	22	10	02.1360.0175
	1,8	46	22	10	02.1360.0180
	1,9	46	22	10	02.1360.0190
	2	49	24	10	02.1360.0200
	2,1	49	24	10	02.1360.0210
	2,2	53	27	10	02.1360.0220
	2,25	53	27	10	02.1360.0225
	2,3	53	27	10	02.1360.0230
	2,4	57	30	10	02.1360.0240
	2,5	57	30	10	02.1360.0250
	2,6	57	30	10	02.1360.0260
	2,7	61	33	10	02.1360.0270
	2,75	61	33	10	02.1360.0275
	2,8	61	33	10	02.1360.0280
	2,9	61	33	10	02.1360.0290
	3	61	33	10	02.1360.0300
	3,1	65	36	10	02.1360.0310
	3,2	65	36	10	02.1360.0320
	3,25	65	36	10	02.1360.0325
	3,3	65	36	10	02.1360.0330
	3,4	70	39	10	02.1360.0340
	3,5	70	39	10	02.1360.0350
	3,6	70	39	10	02.1360.0360
	3,7	70	39	10	02.1360.0370
	3,75	70	39	10	02.1360.0375
	3,8	75	43	10	02.1360.0380
	3,9	75	43	10	02.1360.0390
	4	75	43	10	02.1360.0400
	4,1	75	43	10	02.1360.0410

**DIN
338**

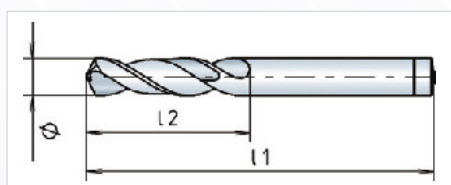



Boren

02.1360. PTG Profi Super HSS spiraalboren

DIN 338, cilindrische schacht, blankgeslepen uitvoering, met kruisaanslijping vanaf 2mm, tophoek 118°.
Verpakt in blauwe kunststof box.

Spiraalboren type 02.1360 HSS

	Ø mm	totale lengte mm	snijlengte mm	verp. eenh.	artikelnr.
	4,2	75	43	10	02.1360.0420
	4,25	75	43	10	02.1360.0425
	4,3	80	47	10	02.1360.0430
	4,4	80	47	10	02.1360.0440
	4,5	80	47	10	02.1360.0450
	4,6	80	47	10	02.1360.0460
	4,7	80	47	10	02.1360.0470
	4,75	80	47	10	02.1360.0475
	4,8	86	52	10	02.1360.0480
	4,9	86	52	10	02.1360.0490
	5,00	86	52	10	02.1360.0500
	5,10	86	52	10	02.1360.0510
	5,20	86	52	10	02.1360.0520
	5,25	86	52	10	02.1360.0525
	5,30	86	52	10	02.1360.0530
	5,40	93	57	10	02.1360.0540
	5,40	93	57	10	02.1360.0550
	5,60	93	57	10	02.1360.0560
	5,70	93	57	10	02.1360.0570
	5,75	93	57	10	02.1360.0575
	5,80	93	57	10	02.1360.0580
	5,90	93	57	10	02.1360.0590
	6,00	93	57	10	02.1360.0600
	6,10	101	63	10	02.1360.0610
	6,20	101	63	10	02.1360.0620
	6,25	101	63	10	02.1360.0625
	6,30	101	63	10	02.1360.0630
	6,40	101	63	10	02.1360.0640
	6,50	101	63	10	02.1360.0650
	6,60	101	63	10	02.1360.0660
	6,70	101	63	10	02.1360.0670
	6,75	109	69	10	02.1360.0675
	6,80	109	69	5	02.1360.0680
	6,90	109	69	5	02.1360.0690
	7,00	109	69	5	02.1360.0700
	7,10	109	69	5	02.1360.0710
	7,20	109	69	5	02.1360.0720
	7,25	109	69	5	02.1360.0725
	7,30	109	69	5	02.1360.0730
	7,40	109	69	5	02.1360.0740
	7,50	109	69	5	02.1360.0750
	7,60	117	75	5	02.1360.0760
	7,70	117	75	5	02.1360.0770
	7,75	117	75	5	02.1360.0775
	7,80	117	75	5	02.1360.0780

**DIN
338**

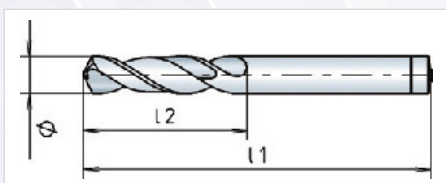



Boren

02.1360. PTG Profi Super HSS spiraalboren

DIN 338, cilindrische schacht, blankgeslepen uitvoering, met kruisaanslijping vanaf 2mm, tophoek 118°.
Verpakt in blauwe kunststof box.

Spiraalboren type 02.1360 HSS

	Ø mm	totale lengte mm	snijlengte mm	verp. eenh.	artikelnr.
	7,90	117	75	5	02.1360.0790
	8,00	117	75	5	02.1360.0800
	8,10	117	75	5	02.1360.0810
	8,20	117	75	5	02.1360.0820
	8,25	117	75	5	02.1360.0825
	8,30	117	75	5	02.1360.0830
	8,40	117	75	5	02.1360.0840
	8,50	117	75	5	02.1360.0850
	8,60	125	81	5	02.1360.0860
	8,70	125	81	5	02.1360.0870
	8,75	125	81	5	02.1360.0875
	8,80	125	81	5	02.1360.0880
	8,90	125	81	5	02.1360.0890
	9,00	125	81	5	02.1360.0900
	9,10	125	81	5	02.1360.0910
	9,20	125	81	5	02.1360.0920
	9,25	125	81	5	02.1360.0925
	9,30	125	81	5	02.1360.0930
	9,40	125	81	5	02.1360.0940
	9,50	125	81	5	02.1360.0950
	9,60	133	87	5	02.1360.0960
	9,70	133	87	5	02.1360.0970
	9,75	133	87	5	02.1360.0975
	9,80	133	87	5	02.1360.0980
	9,90	133	87	5	02.1360.0990
	10,00	133	87	5	02.1360.1000
	10,10	133	87	5	02.1360.1010
	10,20	133	87	5	02.1360.1020
	10,25	133	87	5	02.1360.1025
	10,30	133	87	5	02.1360.1030
	10,40	133	87	5	02.1360.1040
	10,50	133	87	5	02.1360.1050
	10,60	142	94	1	02.1360.1060
	10,70	142	94	1	02.1360.1070
	10,75	142	94	1	02.1360.1075
	10,80	142	94	1	02.1360.1080
	10,90	142	94	1	02.1360.1090
	11,00	142	94	1	02.1360.1100
	11,10	142	94	1	02.1360.1110
	11,20	142	94	1	02.1360.1120
	11,25	142	94	1	02.1360.1125
	11,30	142	94	1	02.1360.1130
	11,40	142	94	1	02.1360.1140
	11,50	142	94	1	02.1360.1150
	11,60	142	94	1	02.1360.1160

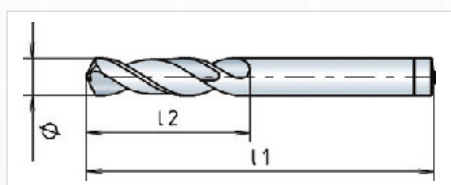

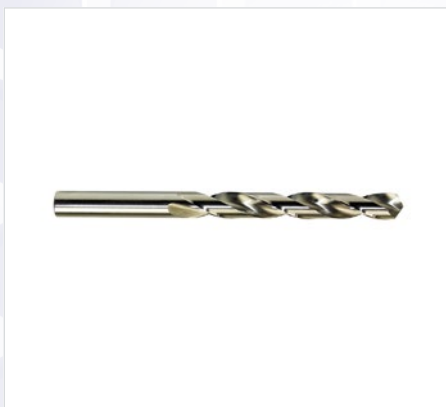
**Boren****02.1360. PTG Profi Super HSS spiraalboren**

DIN 338, cilindrische schacht, blankgeslepen uitvoering, met kruisaanslijping vanaf 2mm, tophoek 118°.
Verpakt in blauwe kunststof box.

Spiraalboren type 02.1360 HSS

	Ø mm	totale lengte mm	snijlengte mm	verp. eenh.	artikelnr.
	11,70	142	94	1	02.1360.1170
	11,75	142	94	1	02.1360.1175
	11,80	142	94	1	02.1360.1180
	11,90	151	101	1	02.1360.1190
	12,00	151	101	1	02.1360.1200
	12,10	15	101	1	02.1360.1210
	12,20	151	101	1	02.1360.1220
	12,25	151	101	1	02.1360.1225
	12,30	151	101	1	02.1360.1230
	12,40	151	101	1	02.1360.1240
	12,50	151	101	1	02.1360.1250
	12,60	15	101	1	02.1360.1260
	12,70	151	101	1	02.1360.1270
	12,75	151	101	1	02.1360.1275
	12,80	151	101	1	02.1360.1280
	12,90	151	101	1	02.1360.1290
	13,00	151	101	1	02.1360.1300
	13,50	160	108	1	02.1360.1350
	14,00	160	108	1	02.1360.1400
	14,50	169	114	1	02.1360.1450
	15,00	169	114	1	02.1360.1500
	15,50	178	120	1	02.1360.1550
	16,00	178	120	1	02.1360.1600

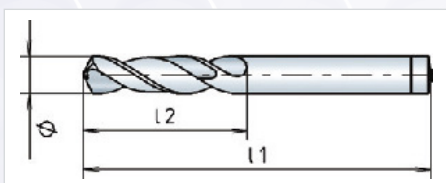
**DIN
338**

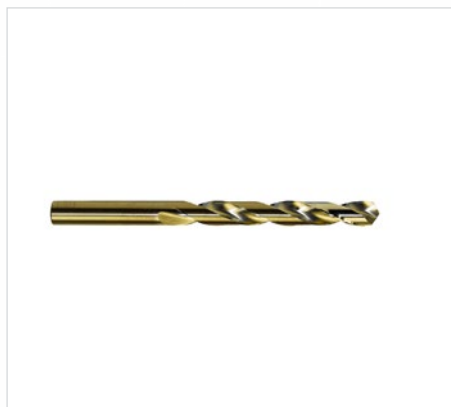

Boren

02.1400. PTG Ratio HSS-Co spiraalboren

DIN 338, cilindrische schacht, "gold-finish" uitvoering, met kruisaanslijping vanaf 2mm, tophoek 130°

Spiraalboren type 02.1400 HSS-Co

	Ø mm	totale lengte mm	snijlengte mm	verp. eenh.	artikelnr.
	1,0	34	12	10	02.1400.0100
	1,1	36	14	10	02.1400.0110
	1,2	38	16	10	02.1400.0120
	1,3	38	16	10	02.1400.0130
	1,4	40	18	10	02.1400.0140
	1,5	40	18	10	02.1400.0150
	1,6	43	20	10	02.1400.0160
	1,7	43	20	10	02.1400.0170
	1,8	46	22	10	02.1400.0180
	1,9	46	22	10	02.1400.0190
	2,0	49	24	10	02.1400.0200
	2,1	49	24	10	02.1400.0210
	2,2	53	27	10	02.1400.0220
	2,3	53	27	10	02.1400.0230
	2,4	57	30	10	02.1400.0240
	2,5	57	30	10	02.1400.0250
	2,6	57	30	10	02.1400.0260
	2,7	61	33	10	02.1400.0270
	2,8	61	33	10	02.1400.0280
	2,9	61	33	10	02.1400.0290
	3,0	61	33	10	02.1400.0300
	3,1	65	36	10	02.1400.0310
	3,2	65	36	10	02.1400.0320
	3,3	65	36	10	02.1400.0330
	3,4	70	39	10	02.1400.0340
	3,5	70	39	10	02.1400.0350
	3,6	70	39	10	02.1400.0360
	3,7	70	39	10	02.1400.0370
	3,8	75	43	10	02.1400.0380
	3,9	75	43	10	02.1400.0390
	4,0	75	43	10	02.1400.0400
	4,1	75	43	10	02.1400.0410
	4,2	75	43	10	02.1400.0420
	4,3	80	47	10	02.1400.0430
	4,4	80	47	10	02.1400.0440
	4,5	80	47	10	02.1400.0450
	4,6	80	47	10	02.1400.0460
	4,7	80	47	10	02.1400.0470
	4,8	86	52	10	02.1400.0480
	4,9	86	52	10	02.1400.0490
	5,0	86	52	10	02.1400.0500
	5,1	86	52	10	02.1400.0510
	5,2	86	52	10	02.1400.0520
	5,3	86	52	10	02.1400.0530
	5,4	93	57	10	02.1400.0540
	5,5	93	57	10	02.1400.0550

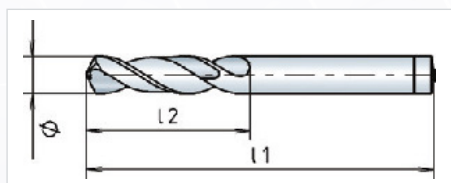
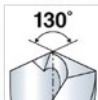
DIN
338

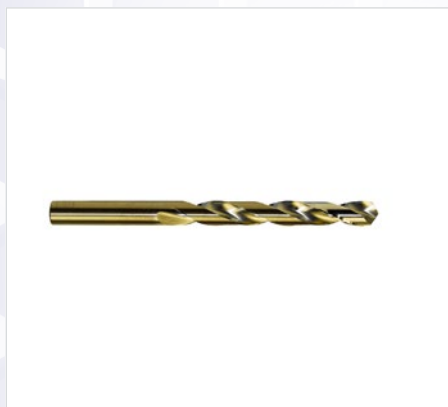
**Boren****02.1400. PTG Ratio HSS-Co spiraalboren**

DIN 338, cilindrische schacht, "gold-finish" uitvoering, met kruisaanslijping vanaf 2mm, tophoek 130°

Spiraalboren type 02.1400 HSS-Co

	Ø mm	totale lengte mm	snijlengte mm	verp. eenh.	artikelnr.
	5,6	93	57	10	02.1400.0560
	5,7	93	57	10	02.1400.0570
	5,8	93	57	10	02.1400.0580
	5,9	93	57	10	02.1400.0590
	6,0	93	57	10	02.1400.0600
	6,1	101	63	10	02.1400.0610
	6,2	101	63	10	02.1400.0620
	6,3	101	63	10	02.1400.0630
	6,4	101	63	10	02.1400.0640
	6,5	101	63	10	02.1400.0650
	6,6	101	63	10	02.1400.0660
	6,7	101	63	10	02.1400.0670
	6,8	109	69	10	02.1400.0680
	6,9	109	69	10	02.1400.0690
	7,0	109	69	10	02.1400.0700
	7,1	109	69	10	02.1400.0710
	7,2	109	69	10	02.1400.0720
	7,3	109	69	10	02.1400.0730
	7,4	109	69	10	02.1400.0740
	7,5	109	69	10	02.1400.0750
	7,6	117	75	10	02.1400.0760
	7,7	117	75	10	02.1400.0770
	7,8	117	75	10	02.1400.0780
	7,9	117	75	10	02.1400.0790
	8,0	117	75	10	02.1400.0800
	8,1	117	75	10	02.1400.0810
	8,2	117	75	10	02.1400.0820
	8,3	117	75	10	02.1400.0830
	8,4	117	75	10	02.1400.0840
	8,5	117	75	10	02.1400.0850
	8,6	125	81	10	02.1400.0860
	8,7	125	81	10	02.1400.0870
	8,8	125	81	10	02.1400.0880
	8,9	125	81	10	02.1400.0890
	9,0	125	81	10	02.1400.0900
	9,1	125	81	10	02.1400.0910
	9,2	125	81	10	02.1400.0920
	9,3	125	81	10	02.1400.0930
	9,4	125	81	10	02.1400.0940
	9,5	125	81	10	02.1400.0950
	9,6	125	81	10	02.1400.0960
	9,7	133	87	10	02.1400.0970
	9,8	133	87	10	02.1400.0980
	9,9	133	87	10	02.1400.0990
	10,0	133	87	10	02.1400.1000
	10,2	133	87	10	02.1400.1020

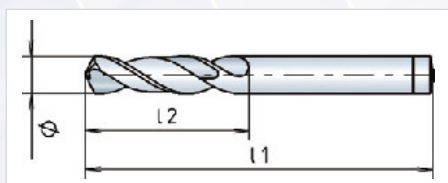
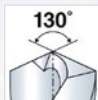
**DIN
338**

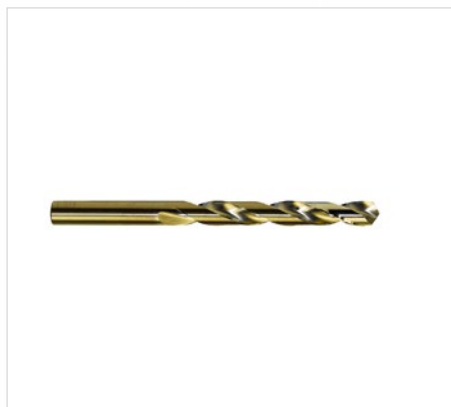

Boren

02.1400. PTG Ratio HSS-Co spiraalboren

DIN 338, cilindrische schacht, "gold-finish" uitvoering, met kruisaanslijping vanaf 2mm, tophoek 130°

Spiraalboren type 02.1400 HSS-Co

	Ø mm	totale lengte mm	snijlengte mm	verp. eenh.	artikelnr.
	10,5	133	87	10	02.1400.1050
	11,0	142	94	5	02.1400.1100
	11,5	142	94	5	02.1400.1150
	12,0	151	101	5	02.1400.1200
	12,5	151	101	5	02.1400.1250
	13,0	151	101	5	02.1400.1300
	13,5	160	108	5	02.1400.1350
	14,0	160	108	5	02.1400.1400
	14,5	169	114	5	02.1400.1450
	15,0	169	114	5	02.1400.1500
	15,5	178	120	5	02.1400.1550
	16,0	178	120	5	02.1400.1600

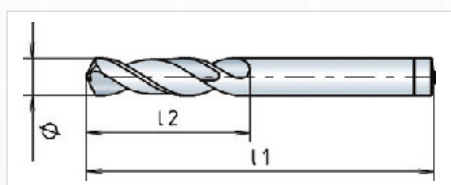

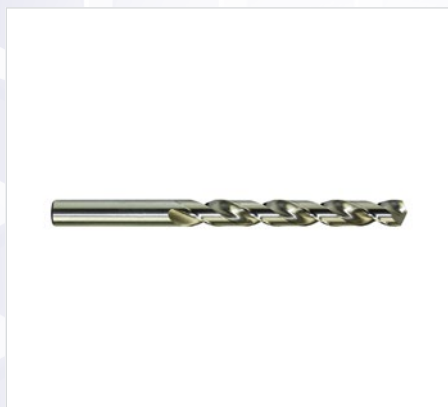

Boren

02.1600. PTG Profi HSS-Co spiraalboren

DIN 338, cilindrische schacht, met kruisaanslijping, vanaf 2mm, tophoek 130°.
Verpakt in rode kunststof box.

Spiraalboren type 02.1600 HSS-Co

	Ø mm	totale lengte mm	snijlengte mm	verp. eenh.	artikelnr.
	0,30	19	3	10	02.1600.0030
	0,40	20	5	10	02.1600.0040
	0,50	22	6	10	02.1600.0050
	0,60	24	7	10	02.1600.0060
	0,70	28	9	10	02.1600.0070
	0,80	30	10	10	02.1600.0080
	0,90	32	11	10	02.1600.0090
	1,00	34	12	10	02.1600.0100
	1,10	36	14	10	02.1600.0110
	1,20	38	16	10	02.1600.0120
	1,30	38	16	10	02.1600.0130
	1,40	40	18	10	02.1600.0140
	1,50	40	18	10	02.1600.0150
	1,60	43	20	10	02.1600.0160
	1,70	43	20	10	02.1600.0170
	1,80	46	22	10	02.1600.0180
	1,90	46	22	10	02.1600.0190
	2,00	49	24	10	02.1600.0200
	2,10	49	24	10	02.1600.0210
	2,20	53	27	10	02.1600.0220
	2,25	53	27	10	02.1600.0225
	2,30	53	27	10	02.1600.0230
	2,40	57	30	10	02.1600.0240
	2,50	57	30	10	02.1600.0250
	2,60	57	30	10	02.1600.0260
	2,70	61	33	10	02.1600.0270
	2,75	61	33	10	02.1600.0275
	2,80	61	33	10	02.1600.0280
	2,90	61	33	10	02.1600.0290
	3,00	61	33	10	02.1600.0300
	3,10	65	36	10	02.1600.0310
	3,20	65	36	10	02.1600.0320
	3,25	65	36	10	02.1600.0325
	3,30	65	36	10	02.1600.0330
	3,40	70	39	10	02.1600.0340
	3,50	70	39	10	02.1600.0350
	3,60	70	39	10	02.1600.0360
	3,70	70	39	10	02.1600.0370
	3,75	70	39	10	02.1600.0375
	3,80	75	43	10	02.1600.0380
	3,90	75	43	10	02.1600.0390
	4,00	75	43	10	02.1600.0400
	4,10	75	43	10	02.1600.0410
	4,20	75	43	10	02.1600.0420
	4,25	75	43	10	02.1600.0425

**DIN
338**

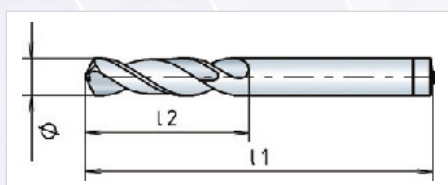



Boren

02.1600. PTG Profi HSS-Co spiraalboren

DIN 338, cilindrische schacht, met kruisaanslijping, vanaf 2mm, tophoek 130°.
Verpakt in rode kunststof box.

Spiraalboren type 02.1600 HSS-Co

	Ø mm	totale lengte mm	snijlengte mm	verp. eenh.	artikelnr.
	4,30	80	47	10	02.1600.0430
	4,40	80	47	10	02.1600.0440
	4,50	80	47	10	02.1600.0450
	4,60	80	47	10	02.1600.0460
	4,70	80	47	10	02.1600.0470
	4,75	80	47	10	02.1600.0475
	4,80	86	52	10	02.1600.0480
	4,90	86	52	10	02.1600.0490
	5,00	86	52	10	02.1600.0500
	5,10	86	52	10	02.1600.0510
	5,20	86	52	10	02.1600.0520
	5,25	86	52	10	02.1600.0525
	5,30	86	52	10	02.1600.0530
	5,40	93	57	10	02.1600.0540
	5,50	93	57	10	02.1600.0550
	5,60	93	57	10	02.1600.0560
	5,70	93	57	10	02.1600.0570
	5,75	93	57	10	02.1600.0575
	5,80	93	57	10	02.1600.0580
	5,90	93	57	10	02.1600.0590
	6,00	93	57	10	02.1600.0600
	6,10	101	63	10	02.1600.0610
	6,20	101	63	10	02.1600.0620
	6,25	101	63	10	02.1600.0625
	6,30	101	63	10	02.1600.0630
	6,40	101	63	10	02.1600.0640
	6,50	101	63	10	02.1600.0650
	6,60	101	63	10	02.1600.0660
	6,70	101	63	10	02.1600.0670
	6,75	109	69	10	02.1600.0675
	6,80	109	69	5	02.1600.0680
	6,90	109	69	5	02.1600.0690
	7,00	109	69	5	02.1600.0700
	7,10	109	69	5	02.1600.0710
	7,20	109	69	5	02.1600.0720
	7,25	109	69	5	02.1600.0725
	7,30	109	69	5	02.1600.0730
	7,40	109	69	5	02.1600.0740
	7,50	109	69	5	02.1600.0750
	7,60	117	75	5	02.1600.0760
	7,70	117	75	5	02.1600.0770
	7,75	117	75	5	02.1600.0775
	7,80	117	75	5	02.1600.0780
	7,90	117	75	5	02.1600.0790
	8,00	117	75	5	02.1600.0800

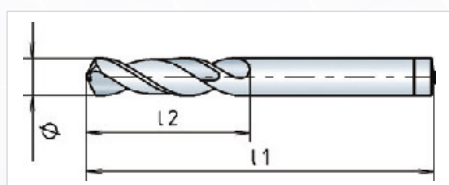



Boren

02.1600. PTG Profi HSS-Co spiraalboren

DIN 338, cilindrische schacht, met kruisaanslijping, vanaf 2mm, tophoek 130°.
Verpakt in rode kunststof box.

Spiraalboren type 02.1600 HSS-Co

	Ø mm	totale lengte mm	snijlengte mm	verp. eenh.	artikelnr.
	8,10	117	75	5	02.1600.0810
	8,20	117	75	5	02.1600.0820
	8,25	117	75	5	02.1600.0825
	8,30	117	75	5	02.1600.0830
	8,40	117	75	5	02.1600.0840
	8,50	117	75	5	02.1600.0850
	8,60	125	81	5	02.1600.0860
	8,70	125	81	5	02.1600.0870
	8,75	125	81	5	02.1600.0875
	8,80	125	81	5	02.1600.0880
	8,90	125	81	5	02.1600.0890
	9,00	125	81	5	02.1600.0900
	9,10	125	81	5	02.1600.0910
	9,20	125	81	5	02.1600.0920
	9,25	125	81	5	02.1600.0925
	9,30	125	81	5	02.1600.0930
	9,40	125	81	5	02.1600.0940
	9,50	125	81	5	02.1600.0950
	9,60	125	81	5	02.1600.0960
	9,70	133	87	5	02.1600.0970
	9,75	133	87	5	02.1600.0975
	9,80	133	87	5	02.1600.0980
	9,90	133	87	5	02.1600.0990
	10,00	133	87	5	02.1600.1000
	10,10	133	87	5	02.1600.1010
	10,20	133	87	5	02.1600.1020
	10,30	133	87	5	02.1600.1030
	10,40	133	87	5	02.1600.1040
	10,50	133	87	5	02.1600.1050
	10,60	142	94	1	02.1600.1060
	10,70	142	94	1	02.1600.1070
	10,80	142	94	1	02.1600.1080
	10,90	142	94	1	02.1600.1090
	11,00	142	94	1	02.1600.1100
	11,10	142	94	1	02.1600.1110
	11,20	142	94	1	02.1600.1120
	11,30	142	94	1	02.1600.1130
	11,40	142	94	1	02.1600.1140
	11,50	142	94	1	02.1600.1150
	11,60	142	94	1	02.1600.1160
	11,70	142	94	1	02.1600.1170
	11,80	142	94	1	02.1600.1180
	11,90	151	101	1	02.1600.1190
	12,00	151	101	1	02.1600.1200
	12,10	151	101	1	02.1600.1210

**DIN
338**

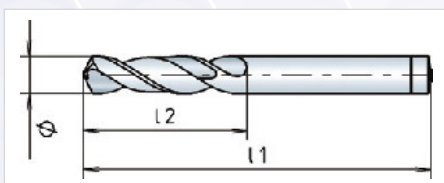



Boren

02.1600. PTG Profi HSS-Co spiraalboren

DIN 338, cilindrische schacht, met kruisaanslijping, vanaf 2mm, tophoek 130°.
Verpakt in rode kunststof box.

Spiraalboren type 02.1600 HSS-Co

	Ø mm	totale lengte mm	snijlengte mm	verp. eenh.	artikelnr.
	12,20	151	101	1	02.1600.1220
	12,30	151	101	1	02.1600.1230
	12,40	151	101	1	02.1600.1240
	12,50	151	101	1	02.1600.1250
	12,60	151	101	1	02.1600.1260
	12,70	151	101	1	02.1600.1270
	12,80	151	101	1	02.1600.1280
	12,90	151	101	1	02.1600.1290
	13,00	151	101	1	02.1600.1300
	13,50	160	108	1	02.1600.1350
	14,00	160	108	1	02.1600.1400
	14,50	169	114	1	02.1600.1450
	15,00	169	114	1	02.1600.1500
	15,50	178	120	1	02.1600.1550
	16,00	178	120	1	02.1600.1600

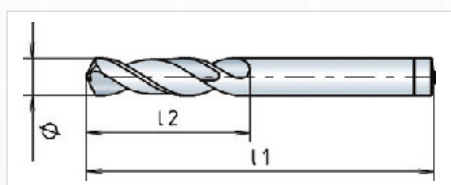

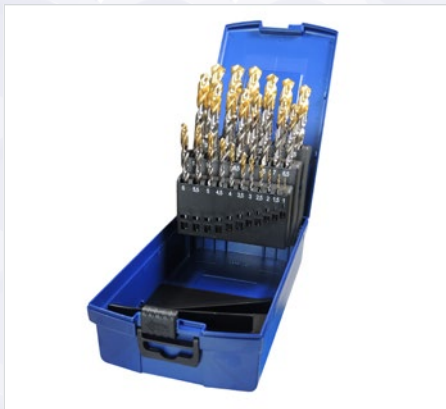
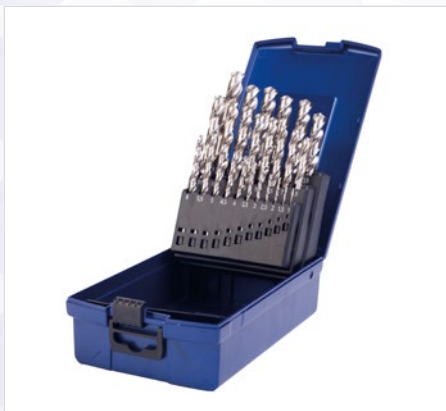

**DIN
338**

Boren	
HSS Profi spiraalborensets	artikelnr.
02.9030 HSS Profi spiraalborenset	
HSS Profi spiraalborenset DIN 338, cilindrische schacht in kunststof cassette	
Set HSS ProfiSuper, 19 delig, afmetingen Ø 1.0 - 10.0x0.5mm oplopend	02.9030.0019
Set HSS ProfiSuper, 25 delig, afmetingen Ø 1.0 - 13.0x0.5mm oplopend	02.9030.0025
02.9035 HSS Profi spiraalborenset	
HSS-Co Profi spiraalborenset DIN 338, cilindrische schacht in kunststof cassette	
Set Profi HSS-Co, 19 delig, afmetingen Ø 1.0 - 10.0x0.5mm oplopend	02.9035.0019
Set Profi HSS-Co, 25 delig, afmetingen Ø 1.0 - 13.0x0.5mm oplopend	02.9035.0025
02.9021 HSS Profi spiraalborenset	
HSS-Eco-Tec spiraalborenset met TiN-tip, DIN 338, cilindrische schacht in kunststof cassette	
Set HSS Eco-Tec, 19 delig, afmetingen Ø 1.0 - 10.0x0.5mm oplopend	02.9021.0019
Set HSS Eco-Tec, 25 delig, afmetingen Ø 1.0 - 13.0x0.5mm oplopend	02.9021.0025



Tappen

03.2050/51 Machinetappen Eventus® HSS, metrisch

DIN 371 en 376 (vanaf M12), tophoek 60°. Met schilaansnijding, 5 gangen. Geschikt voor doorlopende gaten.

Machinetappen Eventus® HSS type 03.2050/51

	Ø1 M	Spoed P	L1	L2	Ø2	□ (a)	verp. eenh.	artikelnr.
	M 3	0,50	56	11	3,5	2,7	1	03.2050.0300
	M 4	0,70	63	13	4,5	3,4	1	03.2050.0400
	M 5	0,80	70	16	6,0	4,3	1	03.2050.0500
	M 6	1,00	80	19	6,0	4,9	1	03.2050.0600
	M 8	1,25	90	22	8,0	6,2	1	03.2050.0800
	M10	1,50	100	24	10,0	8,0	1	03.2050.1000
	M12	1,75	110	29	9,0	7,0	1	03.2051.1200
	M14	2,00	110	30	11,0	9,0	1	03.2051.1400
	M16	2,00	110	32	12,0	9,0	1	03.2051.1600
	M18	2,50	125	34	14,0	11,0	1	03.2051.1800
	M20	2,50	140	34	16,0	12,0	1	03.2051.2000
	M22	2,50	140	34	18,0	14,5	1	03.2051.2200
	M24	3,00	160	38	18,0	14,5	1	03.2051.2400

03.3100/01 Machinetappen Eventus® HSS, metrisch

DIN 371 en 376 (vanaf M12), tophoek 60°. Spiraalhoek 35°. Geschikt voor blinde gaten, aansnijding 2 gangen.

Machinetappen Eventus® HSS type 03.3100/01

	Ø1 M	Spoed P	L1	L2	Ø2	□ (a)	verp. eenh.	artikelnr.
	M 3	0,50	56	11	3,5	2,7	1	03.3100.0300
	M 4	0,70	63	13	4,5	3,4	1	03.3100.0400
	M 5	0,80	70	16	6,0	4,3	1	03.3100.0500
	M 6	1,00	80	19	6,0	4,9	1	03.3100.0600
	M 8	1,25	90	22	8,0	6,2	1	03.3100.0800
	M 10	1,50	100	24	10,0	8,0	1	03.3100.1000
	M12	1,75	110	29	9,0	7,0	1	03.3101.1200
	M14	2,00	110	30	11,0	9,0	1	03.3101.1400
	M16	2,00	110	32	12,0	9,0	1	03.3101.1600
	M18	2,50	125	34	14,0	11,0	1	03.3101.1800
	M20	2,50	140	34	16,0	12,0	1	03.3101.2000
	M22	2,50	140	34	18,0	14,5	1	03.3101.2200
	M24	3,00	160	38	18,0	14,5	1	03.3101.2400

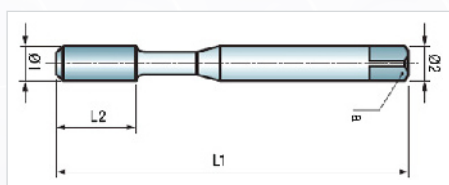

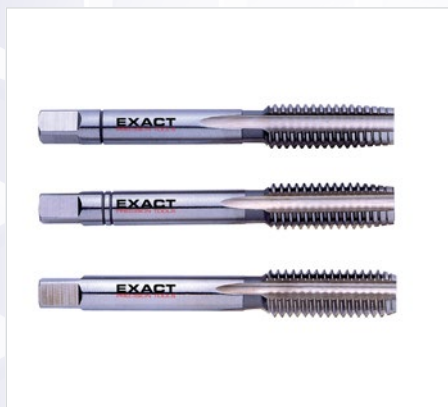

Tappen

03.1120 Handtappen Exact® HSS, metrisch

DIN 352, tophoek 60°. Set van 3 tapjes: voor-, midden- en nasnijder.

Handtappen Exact® HSS type 03.1120

	Ø1 M	Spoed P	L1	L2	Ø2	α (a)	verp. eenh.	artikelnr.
	M 2	0,40	36	8	2,8	2,1	set	03.1120.0200
	M 2,2	0,45	36	9	2,8	2,1	set	03.1120.0220
	M 2,3	0,40	36	9	2,8	2,1	set	03.1120.0230
	M 2,5	0,45	40	9	2,8	2,1	set	03.1120.0250
	M 2,6	0,45	40	9	2,8	2,1	set	03.1120.0260
	M 3	0,50	40	11	3,5	2,7	set	03.1120.0300
	M 3,5	0,60	45	13	4,0	3,0	set	03.1120.0350
	M 4	0,70	45	13	4,5	3,4	set	03.1120.0400
	M 4,5	0,75	50	16	6,0	4,9	set	03.1120.0450
	M 5	0,80	50	16	6,0	4,9	set	03.1120.0500
	M 6	1,00	50	19	6,0	4,9	set	03.1120.0600
	M 7	1,00	50	19	6,0	4,9	set	03.1120.0700
	M 8	1,25	56	22	6,0	4,9	set	03.1120.0800
	M 9	1,25	63	22	7,0	5,5	set	03.1120.0900
	M10	1,50	70	24	7,0	5,5	set	03.1120.1000
	M11	1,50	70	24	8,0	6,2	set	03.1120.1100
	M12	1,75	75	29	9,0	7,0	set	03.1120.1200
	M14	2,00	80	30	11,0	9,0	set	03.1120.1400
	M16	2,00	80	32	12,0	9,0	set	03.1120.1600
	M18	2,50	95	40	14,0	11,0	set	03.1120.1800
	M20	2,50	95	40	16,0	12,0	set	03.1120.2000
	M22	2,50	100	40	18,0	14,5	set	03.1120.2200
	M24	3,00	110	50	18,0	14,5	set	03.1120.2400
	M27	3,00	110	50	20,0	16,0	set	03.1120.2700
	M30	3,50	125	56	22,0	18,0	set	03.1120.3000
	M33	3,50	125	56	25,0	20,0	set	03.1120.3300
	M36	4,00	150	63	28,0	22,0	set	03.1120.3600

**DIN
352**

Hand

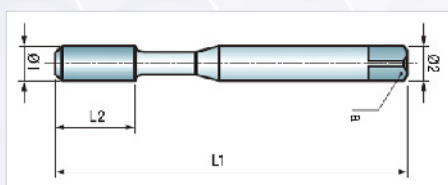



Tappen

03.1220 Handtappen Exact® HSS, metrisch

DIN 2181, tophoek 60°. Set van 2 tapjes: voor-, en nasnijder.

Handtappen Exact® HSS type 03.1220

	Ø1 Mf	Spoed P	L1	L2	Ø2	□ (a)	verp. eenh.	artikelnr.
	Mf3	0,35	40	9	3,5	2,7	set	03.1220.0303
	Mf3,5	0,35	40	9	4,0	3,0	set	03.1220.0353
	Mf4	0,35	45	10	4,5	3,4	set	03.1220.0403
	Mf4	0,50	50	12	6,0	4,9	set	03.1220.0405
	Mf5	0,50	50	12	6,0	4,9	set	03.1220.0505
	Mf5	0,75	50	12	6,0	4,9	set	03.1220.0507
	Mf6	0,50	50	14	6,0	4,9	set	03.1220.0605
	Mf6	0,75	50	14	6,0	4,9	set	03.1220.0607
	Mf7	0,75	50	14	6,0	4,9	set	03.1220.0707
	Mf8	0,50	50	19	6,0	4,9	set	03.1220.0805
	Mf8	0,75	50	19	6,0	4,9	set	03.1220.0807
	Mf8	1,00	56	22	6,0	4,9	set	03.1220.0810
	Mf9	0,75	56	19	7,0	5,5	set	03.1220.0907
	Mf9	1,00	63	22	7,0	5,5	set	03.1220.0910
	Mf10	0,75	63	20	7,0	5,5	set	03.1220.1007
	Mf10	1,00	63	20	7,0	5,5	set	03.1220.1010
	Mf10	1,25	70	24	7,0	5,5	set	03.1220.1012
	Mf11	1,00	63	20	8,0	6,2	set	03.1220.1110
	Mf11	1,25	63	20	8,0	6,2	set	03.1220.1112
	Mf12	0,75	63	22	9,0	7,0	set	03.1220.1207
	Mf12	1,00	70	22	9,0	7,0	set	03.1220.1210
	Mf12	1,25	70	22	9,0	7,0	set	03.1220.1212
	Mf12	1,50	70	22	9,0	7,0	set	03.1220.1215
	Mf13	1,00	70	22	11,0	9,0	set	03.1220.1310
	Mf13	1,50	70	22	11,0	9,0	set	03.1220.1315
	Mf14	0,75	70	22	11,0	9,0	set	03.1220.1407
	Mf14	1,00	70	22	11,0	9,0	set	03.1220.1410
	Mf14	1,25	70	22	11,0	9,0	set	03.1220.1412
	Mf14	1,50	70	22	11,0	9,0	set	03.1220.1415
	Mf15	1,00	70	22	12,0	9,0	set	03.1220.1510
	Mf15	1,50	70	22	12,0	9,0	set	03.1220.1515
	Mf16	1,00	70	22	12,0	9,0	set	03.1220.1610
	Mf16	1,25	70	22	12,0	9,0	set	03.1220.1612
	Mf16	1,50	70	22	12,0	9,0	set	03.1220.1615
	Mf18	1,00	80	22	14,0	11,0	set	03.1220.1810
	Mf18	1,25	80	22	14,0	11,0	set	03.1220.1812
	Mf18	1,50	80	22	14,0	11,0	set	03.1220.1815
	Mf18	2,00	80	22	14,0	11,0	set	03.1220.1820
	Mf20	1,00	80	22	16,0	12,0	set	03.1220.2010
	Mf20	1,25	80	22	16,0	12,0	set	03.1220.2012
	Mf20	1,50	80	22	16,0	12,0	set	03.1220.2015
	Mf20	2,00	80	22	16,0	12,0	set	03.1220.2020
	Mf21	1,50	80	22	16,0	12,0	set	03.1220.2115
	Mf22	1,00	80	22	18,0	14,5	set	03.1220.2210
	Mf22	1,25	80	22	18,0	14,5	set	03.1220.2212
	Mf22	1,50	80	22	18,0	14,5	set	03.1220.2215

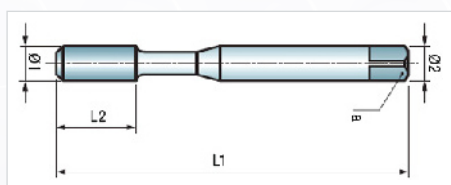

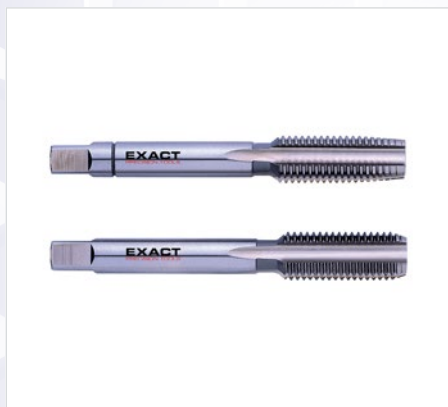

Tappen

03.1220 Handtappen Exact® HSS, metrisch

DIN 2181, tophoek 60°. Set van 2 tapjes: voor-, en nasnijder.

Handtappen Exact® HSS type 03.1220

	Ø1 Mf	Spood P	L1	L2	Ø2	α (a)	verp. eenh.	artikelnr.
	Mf22	2,00	80	22	18,0	14,5	set	03.1220.2220
	Mf23	1,50	80	22	18,0	14,5	set	03.1220.2315
	Mf24	1,00	90	22	18,0	14,5	set	03.1220.2410
	Mf24	1,25	90	22	18,0	14,5	set	03.1220.2412
	Mf24	1,50	90	22	18,0	14,5	set	03.1220.2415
	Mf24	2,00	90	22	18,0	14,5	set	03.1220.2420
	Mf25	1,50	90	22	18,0	14,5	set	03.1220.2515
	Mf26	1,00	90	22	18,0	14,5	set	03.1220.2610
	Mf26	1,50	90	22	18,0	14,5	set	03.1220.2615
	Mf26	2,00	90	22	18,0	14,5	set	03.1220.2620
	Mf27	1,50	90	22	20,0	16,0	set	03.1220.2715
	Mf27	2,00	90	22	20,0	16,0	set	03.1220.2720
	Mf28	1,00	90	22	20,0	16,0	set	03.1220.2810
	Mf28	1,50	90	22	20,0	16,0	set	03.1220.2815
	Mf28	2,00	90	22	20,0	16,0	set	03.1220.2820
	Mf29	1,50	90	22	22,0	16,0	set	03.1220.2915
	Mf30	1,00	90	22	22,0	18,0	set	03.1220.3010
	Mf30	1,50	90	22	22,0	18,0	set	03.1220.3015
	Mf30	2,00	90	22	22,0	18,0	set	03.1220.3020
	Mf30	3,00	125	56	22,0	18,0	set	03.1220.3030
	Mf32	1,50	90	22	22,0	18,0	set	03.1220.3215
	Mf33	1,50	100	25	25,0	20,0	set	03.1220.3315
	Mf33	2,00	100	25	25,0	20,0	set	03.1220.3320
	Mf33	3,00	125	56	25,0	20,0	set	03.1220.3330
	Mf34	1,50	100	25	28,0	22,0	set	03.1220.3415
	Mf34	2,00	100	25	28,0	22,0	set	03.1220.3420
	Mf35	1,50	100	25	28,0	22,0	set	03.1220.3515
	Mf36	1,50	100	25	28,0	22,0	set	03.1220.3615
	Mf36	2,00	100	25	28,0	22,0	set	03.1220.3620
	Mf36	3,00	125	40	28,0	22,0	set	03.1220.3630
	Mf38	1,50	100	25	28,0	22,0	set	03.1220.3815
	Mf39	1,50	110	25	32,0	24,0	set	03.1220.3915
	Mf39	2,00	125	40	32,0	24,0	set	03.1220.3920
	Mf39	3,00	125	40	32,0	24,0	set	03.1220.3930
	Mf40	1,50	110	25	32,0	24,0	set	03.1220.4015
	Mf40	2,00	125	40	32,0	24,0	set	03.1220.4020
	Mf40	3,00	125	40	32,0	24,0	set	03.1220.4030

DIN
2181

Hand

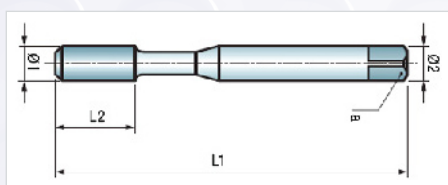



Tappen

03.7110 Ronde snijplaten Exact® HSS, metrisch

DIN 223, tophoek 60°. Voor handgebruik.

Ronde snijplaten Exact® HSS type 03.7110

	Ø1 M	Spoed P	Ø2	Hoogte (h)	verp. eenh.	artikelnr.
	M 2	0,40	16	5	1	03.7110.0200
	M 2,2	0,45	16	5	1	03.7110.0220
	M 2,3	0,40	16	5	1	03.7110.0230
	M 2,5	0,45	16	5	1	03.7110.0250
	M 2,6	0,45	16	5	1	03.7110.0260
	M 3	0,50	20	5	1	03.7110.0300
	M 3,5	0,60	20	5	1	03.7110.0350
	M 4	0,70	20	5	1	03.7110.0400
	M 4,5	0,75	20	7	1	03.7110.0450
	M 5	0,80	20	7	1	03.7110.0500
	M 5,5	0,90	20	7	1	03.7110.0550
	M 6	1,00	20	7	1	03.7110.0600
	M 7	1,00	25	9	1	03.7110.0700
	M 8	1,25	25	9	1	03.7110.0800
	M 9	1,25	25	9	1	03.7110.0900
	M10	1,50	30	11	1	03.7110.1000
	M11	1,50	30	11	1	03.7110.1100
	M12	1,75	38	14	1	03.7110.1200
	M14	2,00	38	14	1	03.7110.1400
	M16	2,00	45	18	1	03.7110.1600
	M18	2,50	45	18	1	03.7110.1800
	M20	2,50	45	18	1	03.7110.2000
	M22	2,50	55	22	1	03.7110.2200
	M24	3,00	55	22	1	03.7110.2400
	M27	3,00	65	25	1	03.7110.2700
	M30	3,50	65	25	1	03.7110.3000
	M33	3,50	65	25	1	03.7110.3300
	M36	4,00	65	25	1	03.7110.3600

DIN
223

Hand

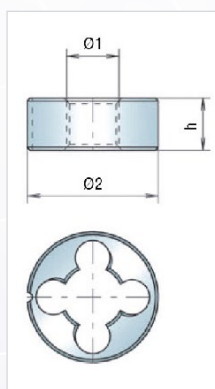
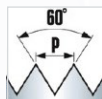



Tappen

03.7210 Ronde snijplaten Exact® HSS, metrisch fijn

DIN 223, tophoek 60°. Voor handgebruik.

Ronde snijplaten Exact® HSS type 03.7210

	Ø1 Mf	Spoed P	Ø2	Hoogte (h)	verp. eenh.	artikelnr.
	M3	0,35	20	5	1	03.7210.0303
	M3,5	0,35	20	5	1	03.7210.0353
	M4	0,35	20	5	1	03.7210.0403
	M4	0,50	20	5	1	03.7210.0405
	M5	0,50	20	5	1	03.7210.0505
	M5	0,75	20	7	1	03.7210.0507
	M6	0,50	20	5	1	03.7210.0605
	M6	0,75	20	7	1	03.7210.0607
	M7	0,75	25	9	1	03.7210.0707
	M8	0,50	25	9	1	03.7210.0805
	M8	0,75	25	9	1	03.7210.0807
	M8	1,00	25	9	1	03.7210.0810
	M9	0,75	25	9	1	03.7210.0907
	M9	1,00	25	9	1	03.7210.0910
	M10	0,75	30	11	1	03.7210.1007
	M10	1,00	30	11	1	03.7210.1010
	M10	1,25	30	11	1	03.7210.1012
	M11	1,00	30	11	1	03.7210.1110
	M11	1,25	30	11	1	03.7210.1112
	M12	0,75	38	10	1	03.7210.1207
	M12	1,00	38	10	1	03.7210.1210
	M12	1,25	38	10	1	03.7210.1212
	M12	1,50	38	10	1	03.7210.1215
	M13	1,00	38	10	1	03.7210.1310
	M13	1,50	38	10	1	03.7210.1315
	M14	0,75	38	10	1	03.7210.1407
	M14	1,00	38	10	1	03.7210.1410
	M14	1,25	38	10	1	03.7210.1412
	M14	1,50	38	10	1	03.7210.1415
	M15	1,00	38	10	1	03.7210.1510
	M15	1,50	38	10	1	03.7210.1515
	M16	1,00	45	14	1	03.7210.1610
	M16	1,25	45	14	1	03.7210.1612
	M16	1,50	45	14	1	03.7210.1615
	M18	1,00	45	14	1	03.7210.1810
	M18	1,25	45	14	1	03.7210.1812
	M18	1,50	45	14	1	03.7210.1815
	M18	2,00	45	14	1	03.7210.1820
	M20	1,00	45	14	1	03.7210.2010
	M20	1,25	45	14	1	03.7210.2012
	M20	1,50	45	14	1	03.7210.2015
	M20	2,00	45	14	1	03.7210.2020
	M21	1,50	55	16	1	03.7210.2115
	M22	1,00	55	16	1	03.7210.2210
	M22	1,25	55	16	1	03.7210.2212
	M22	1,50	55	16	1	03.7210.2215

**DIN
223**

Hand

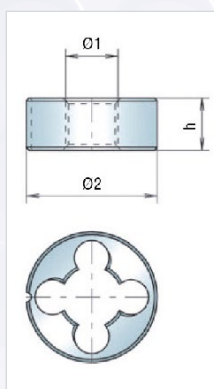



Tappen

03.7210 Ronde snijplaten Exact® HSS, metrisch fijn

DIN 223, tophoek 60°. Voor handgebruik.

Ronde snijplaten Exact® HSS type 03.7210

	Ø1 Mf	Spoed P	Ø2	Hoogte (h)	verp. eenh.	artikelnr.
	M22	2,00	55	16	1	03.7210.2220
	M23	1,50	55	16	1	03.7210.2315
	M24	1,00	55	16	1	03.7210.2410
	M24	1,25	55	16	1	03.7210.2412
	M24	1,50	55	16	1	03.7210.2415
	M24	2,00	55	16	1	03.7210.2420
	M25	1,50	55	16	1	03.7210.2515
	M26	1,00	55	16	1	03.7210.2610
	M26	1,50	55	16	1	03.7210.2615
	M26	2,00	55	16	1	03.7210.2620
	M27	1,50	65	18	1	03.7210.2715
	M27	2,00	65	18	1	03.7210.2720
	M28	1,00	65	18	1	03.7210.2810
	M28	1,50	65	18	1	03.7210.2815
	M28	2,00	65	18	1	03.7210.2820
	M29	1,50	65	18	1	03.7210.2915
	M30	1,00	65	18	1	03.7210.3010
	M30	1,50	65	18	1	03.7210.3015
	M30	2,00	65	18	1	03.7210.3020
	M30	3,00	65	25	1	03.7210.3030
	M32	1,50	65	18	1	03.7210.3215
	M33	1,50	65	18	1	03.7210.3315
	M33	2,00	65	18	1	03.7210.3320
	M33	3,00	65	25	1	03.7210.3330
	M34	1,50	65	18	1	03.7210.3415
	M34	2,00	65	18	1	03.7210.3420
	M35	1,50	65	18	1	03.7210.3515
	M36	1,50	65	18	1	03.7210.3615
	M36	2,00	65	18	1	03.7210.3620
	M36	3,00	65	25	1	03.7210.3630
	M38	1,50	75	20	1	03.7210.3815
	M39	1,50	75	20	1	03.7210.3915
	M39	2,00	75	20	1	03.7210.3920
	M39	3,00	75	20	1	03.7210.3930
	M40	1,50	75	20	1	03.7210.4015
	M40	2,00	75	20	1	03.7210.4020
	M40	3,00	75	20	1	03.7210.4030

DIN
223

Hand

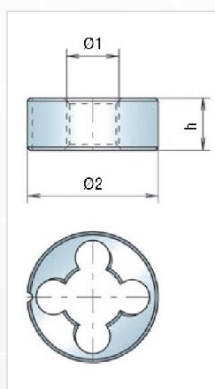
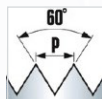

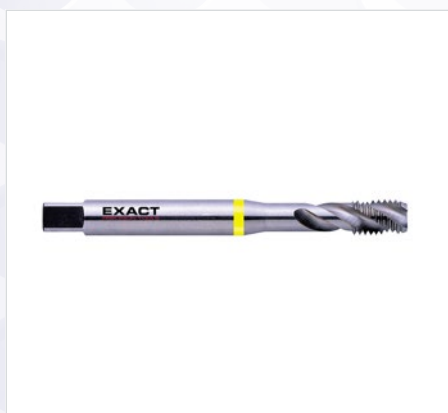

Tappen

03.2100/01 Geelring machinetappen Exact® HSS-Co, metrisch fijn

DIN 371 en 376 (vanaf M12), tophoek 60°. Met schilaansnijding, 5 gangen. Geschikt voor doorlopende gaten. Voorzien van een gele ring.

Geelring machinetappen Exact® HSS-Co, type 03.2100/01

	Ø1 Mf	Spoed P	L1	L2	Ø2	α (a)	verp. eenh.	artikelnr.
	M2	0,40	45	8	2,8	2,1	1	03.2100.0200
	M2,5	0,45	50	9	2,8	2,1	1	03.2100.0250
	M3	0,50	56	11	3,5	2,7	1	03.2100.0300
	M4	0,70	63	13	4,5	3,4	1	03.2100.0400
	M5	0,80	70	16	6,0	4,3	1	03.2100.0500
	M6	1,00	80	19	6,0	4,9	1	03.2100.0600
	M8	1,25	90	22	8,0	6,2	1	03.2100.0800
	M10	1,50	100	24	10,0	8,0	1	03.2100.1000
	M12	1,75	110	29	9,0	7,0	1	03.2101.1200
	M14	2,00	110	30	11,0	9,0	1	03.2101.1400
	M16	2,00	110	32	12,0	9,0	1	03.2101.1600
	M18	2,50	125	34	14,0	11,0	1	03.2101.1800
	M20	2,50	140	34	16,0	12,0	1	03.2101.2000
	M22	2,50	140	34	18,0	14,5	1	03.2101.2200
	M24	3,00	160	38	18,0	14,5	1	03.2101.2400
	M27	3,00	160	38	20,0	16,0	1	03.2101.2700
	M30	3,50	180	45	22,0	18,0	1	03.2101.3000
	M33	3,50	180	50	25,0	20,0	1	03.2101.3300
	M36	4,00	200	56	28,0	22,0	1	03.2101.3600

03.3150/51 Geelring machinetappen Exact® HSS-Co, metrisch

DIN 371 en 376 (vanaf M12), tophoek 60°. Spiraalhoek 35°. Geschikt voor blinde gaten, aansnijding 2 gangen. Voorzien van gele ring.

Geelring machinetappen Exact® HSS-Co, type 03.3150/51

	Ø1 M	Spoed P	L1	L2	Ø2	α (a)	verp. eenh.	artikelnr.
	M2	0,40	45	8	2,8	2,1	1	03.3150.2000
	M2,5	0,45	50	9	2,8	2,1	1	03.3150.0250
	M3	0,50	56	11	3,5	2,7	1	03.3150.0300
	M4	0,70	63	13	4,5	3,4	1	03.3150.0400
	M5	0,80	70	16	6,0	4,3	1	03.3150.0500
	M6	1,00	80	19	6,0	4,9	1	03.3150.0600
	M8	1,25	90	22	8,0	6,2	1	03.3150.0800
	M10	1,50	100	24	10,0	8,0	1	03.3150.1000
	M12	1,75	110	29	9,0	7,0	1	03.3151.1200
	M14	2,00	110	30	11,0	9,0	1	03.3151.1400
	M16	2,00	110	32	12,0	9,0	1	03.3151.1600
	M18	2,50	125	34	14,0	11,0	1	03.3151.1800
	M20	2,50	140	34	16,0	12,0	1	03.3151.2000
	M22	2,50	140	34	18,0	14,5	1	03.3151.2200
	M24	3,00	160	38	18,0	14,5	1	03.3151.2400
	M27	3,00	160	38	20,0	16,0	1	03.3151.2700
	M30	3,50	180	45	22,0	18,0	1	03.3151.3000
	M33	3,50	180	50	25,0	20,0	1	03.3151.3300
	M36	4,00	200	56	28,0	22,0	1	03.3151.3600

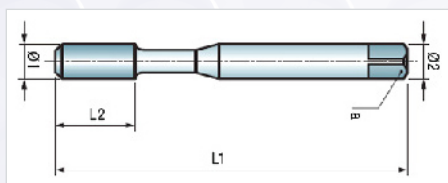



Tappen

03.3500 Geelring machinetappen Exact® HSS-Co, metrisch fijn

DIN 374, tophoek 60°. Met schilaansnijding, 4-5 gangen. Geschikt voor doorlopende gaten. Voorzien van een gele ring.

Geelring machinetappen Exact® HSS-Co, type 03.3500

	Ø1 Mf	Spoed P	L1	L2	Ø2	□ (a)	verp. eenh.	artikelnr.
	Mf6	0,75	80	14	4,5	3,4	1	03.3500.0607
	Mf8	0,75	80	19	6,0	4,9	1	03.3500.0807
	Mf8	1,00	90	22	6,0	4,9	1	03.3500.0810
	Mf10	1,00	90	16	7,0	5,5	1	03.3500.1010
	Mf10	1,25	100	24	7,0	5,5	1	03.3500.1012
	Mf12	1,00	100	22	9,0	7,0	1	03.3500.1210
	Mf12	1,25	100	22	9,0	7,0	1	03.3500.1212
	Mf12	1,50	100	22	9,0	7,0	1	03.3500.1215
	Mf14	1,00	100	22	11,0	9,0	1	03.3500.1410
	Mf14	1,25	100	22	11,0	9,0	1	03.3500.1412
	Mf14	1,50	100	22	11,0	9,0	1	03.3500.1415
	Mf16	1,00	100	22	12,0	9,0	1	03.3500.1610
	Mf16	1,50	100	22	12,0	9,0	1	03.3500.1615
	Mf18	1,00	110	22	14,0	11,0	1	03.3500.1810
	Mf18	1,50	110	25	14,0	11,0	1	03.3500.1815
	Mf18	2,00	125	34	14,0	11,0	1	03.3500.1820
	Mf20	1,00	125	25	16,0	12,0	1	03.3500.2010
	Mf20	1,50	125	25	16,0	12,0	1	03.3500.2015
	Mf20	2,00	140	34	16,0	12,0	1	03.3500.2020
	Mf22	1,00	125	25	18,0	14,5	1	03.3500.2210
	Mf22	1,50	125	25	18,0	14,5	1	03.3500.2215
	Mf22	2,00	140	34	18,0	14,5	1	03.3500.2220
	Mf24	1,00	140	28	18,0	14,5	1	03.3500.2410
	Mf24	1,50	140	28	18,0	14,5	1	03.3500.2415
	Mf24	2,00	140	28	18,0	14,5	1	03.3500.2420
	Mf26	1,50	140	28	18,0	14,5	1	03.3500.2615
	Mf27	2,00	140	28	20,0	16,0	1	03.3500.2720
	Mf28	1,50	150	28	22,0	18,0	1	03.3500.2815
	Mf30	1,50	150	28	22,0	18,0	1	03.3500.3015
	Mf30	2,00	150	28	22,0	18,0	1	03.3500.3020
	Mf32	1,50	150	28	22,0	18,0	1	03.3500.3215
	Mf35	1,50	170	30	28,0	22,0	1	03.3500.3515
	Mf36	1,50	170	28	28,0	22,0	1	03.3500.3615
	Mf38	1,50	170	28	28,0	22,0	1	03.3500.3815
	Mf40	1,50	170	30	32,0	24,0	1	03.3500.4015
	Mf42	1,50	170	30	32,0	24,0	1	03.3500.4215
	Mf45	1,50	180	32	36,0	29,0	1	03.3500.4515
	Mf48	1,50	190	32	36,0	29,0	1	03.3500.4815
	Mf50	1,50	190	32	36,0	29,0	1	03.3500.5015
	Mf52	1,50	190	32	40,0	32,0	1	03.3500.5215

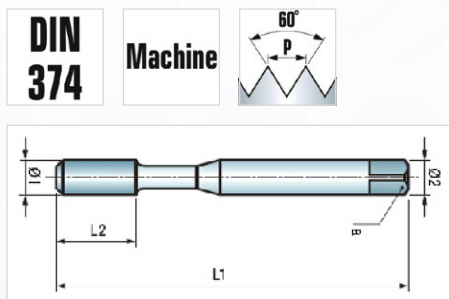

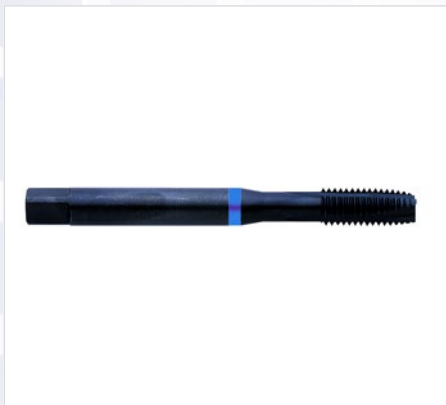

Tappen

03.2250/51 Blauwring machinetappen Exact® HSS-Co, metrisch

DIN 371 en 376 (vanaf M12), tophoek 60°. Met schilaansnijding, 5 gangen.

Genitreerde uitvoering speciaal voor RVS. Geschikt voor doorlopende gaten. Voorzien van een blauwe ring.

Blauwring machinetappen Exact® HSS-Co, type 03.2250/51

	Ø1 M	Spoed P	L1	L2	Ø2	α (a)	verp. eenh.	artikelnr.
	M3	0,50	56	11	3,5	2,7	1	03.2250.0300
	M4	0,70	63	13	4,5	3,4	1	03.2250.0400
	M5	0,80	70	16	6,0	4,3	1	03.2250.0500
	M6	1,00	80	19	6,0	4,9	1	03.2250.0600
	M8	1,25	90	22	8,0	6,2	1	03.2250.0800
	M10	1,50	100	24	10,0	8,0	1	03.2250.1000
	M12	1,75	110	29	9,0	7,0	1	03.2251.1200
	M14	2,00	110	30	11,0	9,0	1	03.2251.1400
	M16	2,00	110	32	12,0	9,0	1	03.2251.1600
	M18	2,50	125	34	14,0	11,0	1	03.2251.1800
	M20	2,50	140	34	16,0	12,0	1	03.2251.2000
	M22	2,50	140	34	18,0	14,5	1	03.2251.2200
	M24	3,00	160	38	18,0	14,5	1	03.2251.2400

03.3250/51 Blauwring machinetappen Exact® HSS-Co, metrisch

DIN 371 en 376 (vanaf M12), tophoek 60°. Spiraalhoek 35°, aansnijding 2 gangen.

Genitreerde uitvoering speciaal voor RVS. Geschikt voor blinde gaten. Voorzien van een blauwe ring.

Blauwring machinetappen Exact® HSS-Co, type 03.3250/51

	Ø1 M	Spoed P	L1	L2	Ø2	α (a)	verp. eenh.	artikelnr.
	M3	0,50	56	11	3,5	2,7	1	03.3250.0300
	M4	0,70	63	13	4,5	3,4	1	03.3250.0400
	M5	0,80	70	16	6,0	4,3	1	03.3250.0500
	M6	1,00	80	19	6,0	4,9	1	03.3250.0600
	M8	1,25	90	22	8,0	6,2	1	03.3250.0800
	M10	1,50	100	24	10,0	8,0	1	03.3250.1000
	M12	1,75	110	29	9,0	7,0	1	03.3251.1200
	M14	2,00	110	30	11,0	9,0	1	03.3251.1400
	M16	2,00	110	32	12,0	9,0	1	03.3251.1600
	M18	2,50	125	34	14,0	11,0	1	03.3251.1800
	M20	2,50	140	34	16,0	12,0	1	03.3251.2000
	M22	2,50	140	34	18,0	14,5	1	03.3251.2200
	M24	3,00	160	38	18,0	14,5	1	03.3251.2400

**DIN
371**

**DIN
376**

Machine

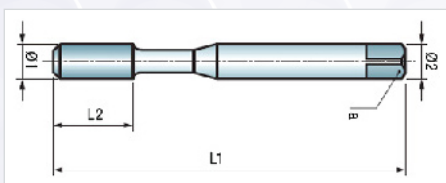



Tappen

03.3900 Blauwring machinetappen Exact® HSS-Co, metrisch fijn

DIN 374, tophoek 60°. Met schilaansnijding, 4-5 gangen.

Genitreerde uitvoering speciaal voor RVS. Geschikt voor doorlopende gaten. Voorzien van een blauwe ring.

Blauwring machinetappen Exact® HSS-Co, type 03.3900

	Ø1 Mf	Spoed P	L1	L2	Ø2	□ (a)	verp. eenh.	artikelnr.
	Mf6	0,75	80	14	4,5	3,4	1	03.3900.0607
	Mf8	0,75	80	19	6,0	4,9	1	03.3900.0807
	Mf8	1,00	90	22	6,0	4,9	1	03.3900.0810
	Mf10	1,00	90	16	7,0	5,5	1	03.3900.1010
	Mf10	1,25	100	24	7,0	5,5	1	03.3900.1012
	Mf12	1,00	100	22	9,0	7,0	1	03.3900.1210
	Mf12	1,25	100	22	9,0	7,0	1	03.3900.1212
	Mf12	1,50	100	22	9,0	7,0	1	03.3900.1215
	Mf14	1,00	100	22	11,0	9,0	1	03.3900.1410
	Mf14	1,25	100	22	11,0	9,0	1	03.3900.1412
	Mf14	1,50	100	22	11,0	9,0	1	03.3900.1415
	Mf16	1,00	100	22	12,0	9,0	1	03.3900.1610
	Mf16	1,50	100	22	12,0	9,0	1	03.3900.1615
	Mf18	1,00	110	22	14,0	11,0	1	03.3900.1810
	Mf18	1,50	110	25	14,0	11,0	1	03.3900.1815
	Mf18	2,00	125	34	14,0	11,0	1	03.3900.1820
	Mf20	1,00	125	25	16,0	12,0	1	03.3900.2010
	Mf20	1,50	125	25	16,0	12,0	1	03.3900.2015
	Mf20	2,00	140	34	16,0	12,0	1	03.3900.2020
	Mf22	1,00	125	25	18,0	14,5	1	03.3900.2210
	Mf22	1,50	125	25	18,0	14,5	1	03.3900.2215
	Mf22	2,00	140	34	18,0	14,5	1	03.3900.2220
	Mf24	1,00	140	28	18,0	14,5	1	03.3900.2410
	Mf24	1,50	140	28	18,0	14,5	1	03.3900.2415

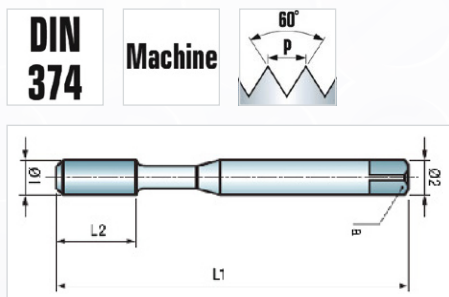

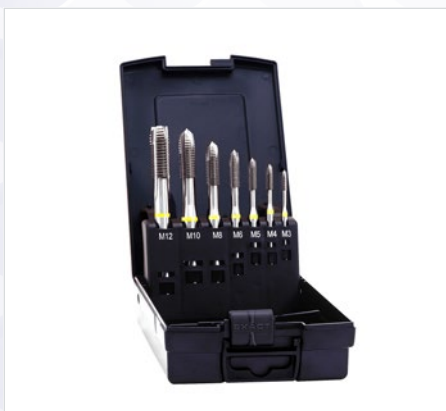

Tappen

HSS Machinetappen Sets

artikelnr.

03.9250. Eventus® Machinetappen (combi) sets

Set machinetappen inclusief boren in de bijbehorende voorboormaten. Deze sets zijn in HSS als in HSS-Co leverbaar, beide in een kunststof cassette.

Set HSS machinetappen + boren in voorboormaten. M3-M12 in kunststof cassette

03.9250.1000

Set HSS-Co machinetappen + boren in voorboormaten. M3-M12 in kunststof cassette

03.9250.1100

03.9220. Exact® HSS-Co machinetappen sets, metrisch

Set HSS-Co machinetappen met de geelring tappen. Een set voor zowel blinde als doorlopende gaten. Allen geleverd in een kunststof cassette.

Geelring vorm B voor doorlopende gaten, 7-delige set, M3-M12

03.9220.1000

Geelring gespiraliseerd 35° voor blinde gaten, 7-delige set, M3-M12

03.9220.5000

03.9220. Exact® HSS-Co machinetappen sets, metrisch

Set HSS-Co machinetappen met de blauwring tappen. Een set voor zowel blinde als doorlopende gaten. Allen geleverd in een kunststof cassette.

Blauwring vorm B voor doorlopende gaten, 7-delige set, M3-M12

03.9220.1500

Blauwring gespiraliseerd 35° voor blinde gaten, 7-delige set, M3-M12

03.9220.5500



Verzinken

05.3300 Verzinkfrees Exact® HSS

DIN 335C, 3 snijkanten, 90° en een cilindrische schacht.

Verzinkfrees Exact® HSS, type 05.3300

	Ø1	Ø2	L1	schacht Ø	artikelnr.
	4,3	1,3	40	4	05.3300.0430
	5,0	1,5	40	4	05.3300.0500
	5,3	1,5	40	4	05.3300.0530
	5,8	1,5	45	5	05.3300.0580
	6,0	1,5	45	5	05.3300.0600
	6,3	1,5	45	5	05.3300.0630
	7,0	1,8	50	6	05.3300.0700
	7,3	1,8	50	6	05.3300.0730
	8,0	2,0	50	6	05.3300.0800
	8,3	2,0	50	6	05.3300.0830
	9,4	2,2	50	6	05.3300.0940
	10,0	2,5	50	6	05.3300.1000
	10,4	2,5	50	6	05.3300.1040
	11,5	2,8	56	8	05.3300.1150
	12,4	2,8	56	8	05.3300.1240
	13,4	2,9	56	8	05.3300.1340
	15,0	3,2	60	10	05.3300.1500
	16,5	3,2	60	10	05.3300.1650
	19,0	3,5	63	10	05.3300.1900
	20,5	3,5	63	10	05.3300.2050
	23,0	3,8	67	10	05.3300.2300
	25,0	3,8	67	10	05.3300.2500
	28,0	4,0	71	12	05.3300.2800
	30,0	4,2	71	12	05.3300.3000
	31,0	4,2	71	12	05.3300.3100
	40,0	5,0	80	15	05.3300.4000

**DIN
335C**

**3
snijder**

90°



Verzinken					
05.3301 Verzinkfrees Exact® HSS, TiN gecoat					
DIN 335C, 3 snijkanten, 90°, een cilindrische schacht en TiN coating.					
Verzinkfrees Exact® HSS TiN gecoat, type 05.3301					
	Ø1	Ø2	L1	schacht Ø	artikelnr.
	4,3	1,3	40	4	05.3301.0430
	5,0	1,5	40	4	05.3301.0500
	5,3	1,5	40	4	05.3301.0530
	5,8	1,5	45	5	05.3301.0580
	6,0	1,5	45	5	05.3301.0600
	6,3	1,5	45	5	05.3301.0630
	7,0	1,8	50	6	05.3301.0700
	7,3	1,8	50	6	05.3301.0730
	8,0	2,0	50	6	05.3301.0800
	8,3	2,0	50	6	05.3301.0830
	9,4	2,2	50	6	05.3301.0940
	10,0	2,5	50	6	05.3301.1000
	10,4	2,5	50	6	05.3301.1040
	11,5	2,8	56	8	05.3301.1150
	12,4	2,8	56	8	05.3301.1240
	13,4	2,9	56	8	05.3301.1340
	15,0	3,2	60	10	05.3301.1500
	16,5	3,2	60	10	05.3301.1650
	19,0	3,5	63	10	05.3301.1900
	20,5	3,5	63	10	05.3301.2050
	23,0	3,8	67	10	05.3301.2300
	25,0	3,8	67	10	05.3301.2500
	28,0	4,0	71	12	05.3301.2800
	30,0	4,2	71	12	05.3301.3000
	31,0	4,2	71	12	05.3301.3100
	40,0	5,0	80	15	05.3301.4000

DIN
335C

TiN

3
snijder

90°

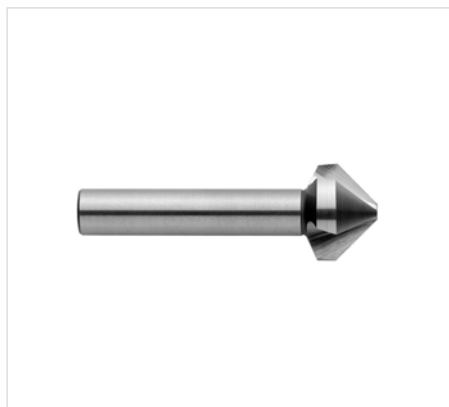

**DIN
335C**

**3
snijder**

90°

TiN

TiAlN

Verzinken

05.3320 Verzinkfrees Exact®-Co HSS

DIN 335C, 3 snijkanten, 90° en een cilindrische schacht.

Verzinkfrees Exact® HSS-Co, type 05.3320

	Ø1	Ø2	L1	schacht Ø	artikelnr.
	6,3	1,5	45	5	05.3320.0630
	8,3	2,0	50	6	05.3320.0830
	10,4	2,5	50	6	05.3320.1040
	12,4	2,8	56	8	05.3320.1240
	16,5	3,2	60	10	05.3320.1650
	20,5	3,5	63	10	05.3320.2050
	25,0	3,8	67	10	05.3320.2500
	31,0	4,2	71	12	05.3320.3100

05.3321 Verzinkfrees Exact® HSS-Co, TiN gecoat

DIN 335C, 3 snijkanten, 90°, een cilindrische schacht en TiN coating.

Verzinkfrees Exact® HSS-Co TiN gecoat, type 05.3321

	Ø1	Ø2	L1	schacht Ø	artikelnr.
	6,3	1,5	45	5	05.3321.0630
	8,3	2,0	50	6	05.3321.0830
	10,4	2,5	50	6	05.3321.1040
	12,4	2,8	56	8	05.3321.1240
	16,5	3,2	60	10	05.3321.1650
	20,5	3,5	63	10	05.3321.2050
	25,0	3,8	67	10	05.3321.2500
	31,0	4,2	71	12	05.3321.3100

05.3323 Verzinkfrees Exact® HSS-Co, TiAlN gecoat

DIN 335C, 3 snijkanten, 90°, een cilindrische schacht en TiAlN coating.

Verzinkfrees Exact® HSS-Co TiAlN gecoat, type 05.3323

	Ø1	Ø2	L1	schacht Ø	artikelnr.
	6,3	1,5	45	5	05.3323.0630
	8,3	2,0	50	6	05.3323.0830
	10,4	2,5	50	6	05.3323.1040
	12,4	2,8	56	8	05.3323.1240
	16,5	3,2	60	10	05.3323.1650
	20,5	3,5	63	10	05.3323.2050
	25,0	3,8	67	10	05.3323.2500
	31,0	4,2	71	12	05.3323.3100

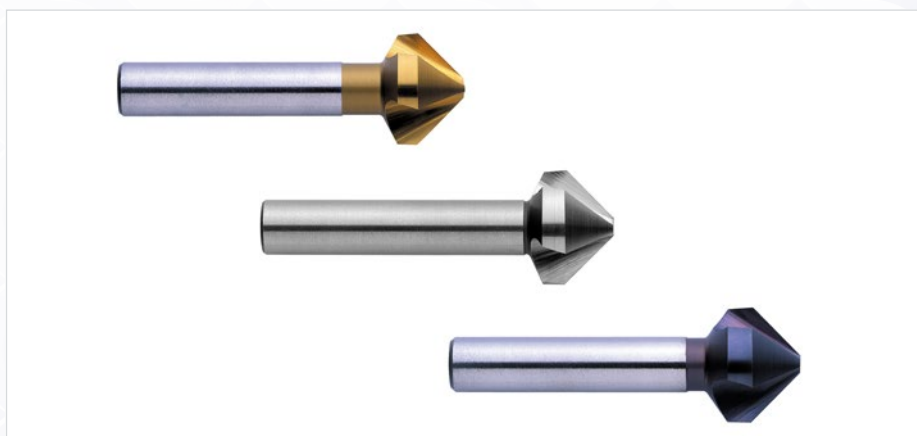



2
snijder

TiN

TiAlN

Verzinken

05.6500 Exact® HSS trappenboor

Met een rechte spaangroef, 2 snijkanten, kruisaanslijping en een cilindrische schacht met 3 meeneem vlakjes.

Trappenboor Exact® HSS, type 05.6500

Ø mm	Traphoogte	L1	schacht Ø	artikelnr.
4-5-6-7-8-9-10-11-12	5	80	6	05.6500.0412
4-6-8-10-12-14-16-18-20	4	67	8	05.6500.0420
6-8-10-12-14-16-18-20-22-24-26-28-30	4	98	10	05.6500.0630
9-12-15-18-21-24-27-30-33-36	3	86	12	05.6500.0936
12-13-14-15-16-17-18-19-20	4	76	9	05.6500.1220
20-21-22-23-24-25-26-27-28-29-30	4	88	12	05.6500.2030
30-31-32-33-34-35-36-37-38-39-40	4	98	13	05.6500.3040
40-41-42-43-44-45-46-47-48-49-50	4	107	13	05.6500.4050
50-51-52-53-54-55-56-57-58-59-60	4	120	13	05.6500.5060

05.6501 Exact® HSS trappenboor. TiN gecoat

Met een rechte spaangroef, 2 snijkanten, kruisaanslijping en een cilindrische schacht met 3 meeneem vlakjes en TiN gecoat.

Trappenboor Exact® HSS, type 05.6501, TiN gecoat

Ø mm	Traphoogte	L1	schacht Ø	artikelnr.
4-5-6-7-8-9-10-11-12	5	80	6	05.6501.0412
4-6-8-10-12-14-16-18-20	4	67	8	05.6501.0420
6-8-10-12-14-16-18-20-22-24-26-28-30	4	98	10	05.6501.0630
9-12-15-18-21-24-27-30-33-36	3	86	12	05.6501.0936
12-13-14-15-16-17-18-19-20	4	76	9	05.6501.1220
20-21-22-23-24-25-26-27-28-29-30	4	88	12	05.6501.2030
30-31-32-33-34-35-36-37-38-39-40	4	98	13	05.6501.3040
40-41-42-43-44-45-46-47-48-49-50	4	107	13	05.6501.4050
50-51-52-53-54-55-56-57-58-59-60	4	120	13	05.6501.5060

05.6503 Exact® HSS trappenboor. TiAlN gecoat

Met een rechte spaangroef, 2 snijkanten, kruisaanslijping en een cilindrische schacht met 3 meeneem vlakjes en TiAlN gecoat.

Trappenboor Exact® HSS, type 05.6503, TiAlN gecoat

Ø mm	Traphoogte	L1	schacht Ø	artikelnr.
4-5-6-7-8-9-10-11-12	5	80	6	05.6503.0412
4-6-8-10-12-14-16-18-20	4	67	8	05.6503.0420
6-8-10-12-14-16-18-20-22-24-26-28-30	4	98	10	05.6503.0630
9-12-15-18-21-24-27-30-33-36	3	86	12	05.6503.0936
12-13-14-15-16-17-18-19-20	4	76	9	05.6503.1220
20-21-22-23-24-25-26-27-28-29-30	4	88	12	05.6503.2030
30-31-32-33-34-35-36-37-38-39-40	4	98	13	05.6503.3040
40-41-42-43-44-45-46-47-48-49-50	4	107	13	05.6503.4050
50-51-52-53-54-55-56-57-58-59-60	4	120	13	05.6503.5060





Verzinken

Sets Verzinkfrezen	artikelnr.
05.9330 Set Exact® HSS Verzinkfrezen	
5- of 6-delige set verzinkfrezen DIN 335C, 3 snijkanten, 90° en een cilindrische schacht.	
Set Exact HSS verzinkfrezen, 90°, 3 snijkanten, inhoud: 6,3 / 8,3 / 10,4 / 12,4 / 16,5 / 20,5	05.9330.2050
Set Exact HSS verzinkfrezen, 90°, 3 snijkanten, inhoud: 6,3 / 10,4 / 16,5 / 20,5 / 25,0	05.9330.2500

05.9331 Set Exact® HSS Verzinkfrezen, TiN gecoat

5- of 6-delige set verzinkfrezen DIN 335C, 3 snijkanten, 90°, een cilindrische schacht en TiN coating.	
Set Exact HSS verzinkfrezen, 90°, 3 snijkanten, TiN gecoat, inhoud: 6,3 / 8,3 / 10,4 / 12,4 / 16,5 / 20,5	05.9331.2050
Set Exact HSS verzinkfrezen, 90°, 3 snijkanten, TiN gecoat, inhoud: 6,3 / 10,4 / 16,5 / 20,5 / 25,0	05.9331.2500

05.9340 Exact® HSS-Co Verzinkfrezen

6-delige set verzinkfrezen DIN 335C, 3 snijkanten, 90° en een cilindrische schacht.	
Set Exact HSS-Co verzinkfrezen, 90°, 3 snijkanten, inhoud: 6,3 / 8,3 / 10,4 / 12,4 / 16,5 / 20,5	05.9340.2050

Sets Trappenboren

Sets Trappenboren	artikelnr.
05.9650 Set Exact® HSS Trappenboren	
3-delige set. Rechte spaangroef, 2 snijkanten, kruisaanslijping en een cilindrische schacht met 3 meeneem vlakjes.	
Set Exact HSS trappenboren, inhoud: 4-12 / 4-20 / 6-30	05.9650.2000

05.9651 Set Exact® HSS Trappenboren, TiN gecoat

3-delige set. Rechte spaangroef, 2 snijkanten, kruisaanslijping, een cilindrische schacht met 3 meeneem vlakjes en TiN gecoat.	
Set Exact HSS trappenboren, TiN gecoat, inhoud: 4-12 / 4-20 / 6-30	05.9651.2000

05.9653. Set Exact® HSS trappenboren, TiAlN gecoat

3-delige set. Rechte spaangroef, 2 snijkanten, kruisaanslijping, een cilindrische schacht met 3 meeneem vlakjes en TiAlN gecoat.	
Set Exact HSS trappenboren, TiAlN gecoat, inhoud: 4-12 / 4-20 / 6-30	05.9653.2000



Typefouten voorbehouden.

Beelden kunnen afwijken van de werkelijke producten.

Niets uit deze uitgave mag worden verveelvoudigd, opgeslagen in een geautomatiseerd gegevensbestand en/of openbaar gemaakt in enige vorm of op enige wijze, hetzij elektronisch, mechanisch, door fotokopieën, opnamen of op enige andere manier zonder voorafgaande schriftelijke toestemming van Kurval.